

NordicTrack®

COMMERCIAL S10i STUDIO CYCLE

Model No. NTEVEX14718.0

Serial No. _____

Write the serial number in the space above for reference.

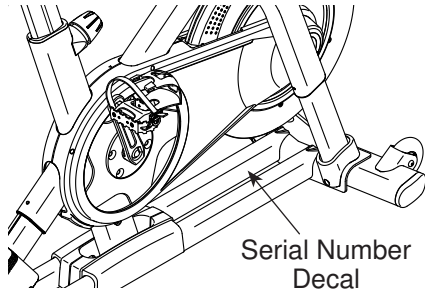

USER'S MANUAL

CUSTOMER SERVICE

UNITED KINGDOM

Call: 0330 123 1045

From Ireland: 053 92 36102

Website: iconsupport.eu

E-mail: csuk@iconeurope.com

Write:

ICON Health & Fitness, Ltd.

Unit 4, Westgate Court

Silkwood Park

OSSETT

WF5 9TT

UNITED KINGDOM

AUSTRALIA

Call: 1800 993 770

E-mail: australiacc@iconfitness.com

Write:

ICON Health & Fitness

PO Box 635

WINSTON HILLS NSW 2153

AUSTRALIA

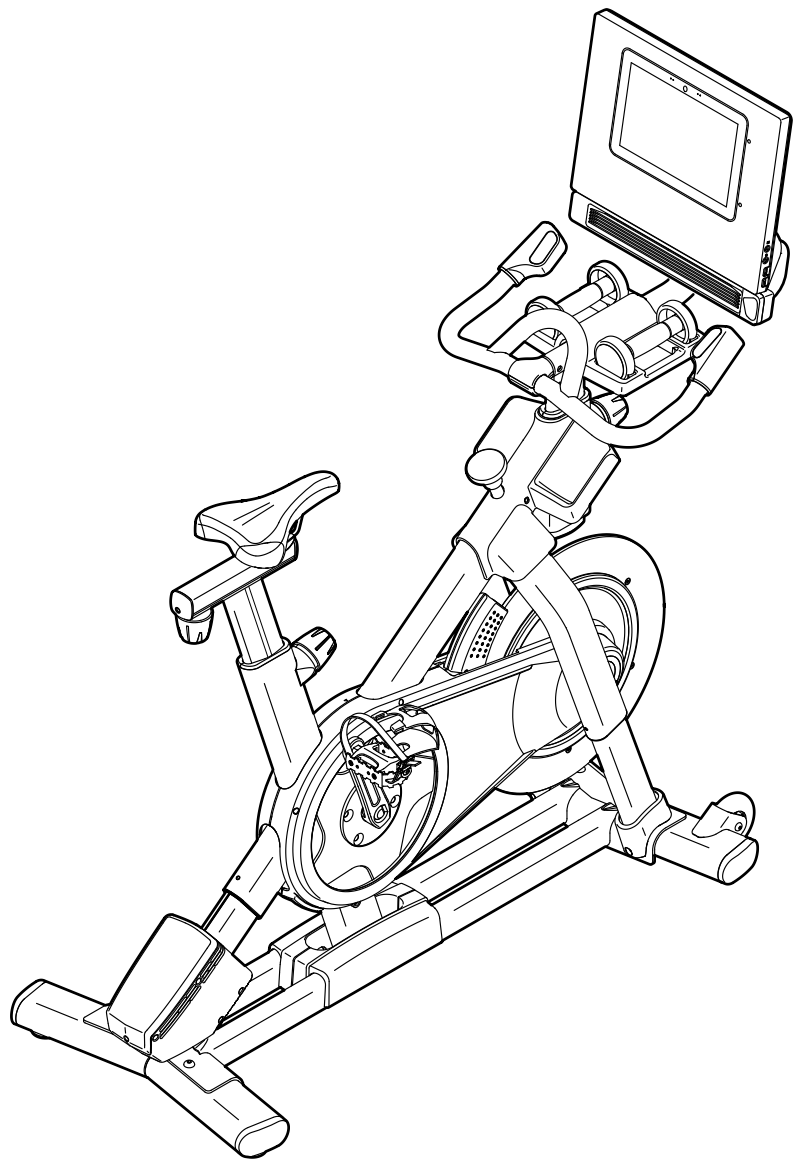

⚠ CAUTION

Read all precautions and instructions in this manual before using this equipment. Keep this manual for future reference.

TABLE OF CONTENTS

WARNING DECAL PLACEMENT	2
IMPORTANT PRECAUTIONS	3
BEFORE YOU BEGIN	5
PART IDENTIFICATION CHART	6
ASSEMBLY	7
HOW TO USE THE STUDIO CYCLE	15
MAINTENANCE AND TROUBLESHOOTING	30
EXERCISE GUIDELINES	33
PART LIST	36
EXPLODED DRAWING	38
ORDERING REPLACEMENT PARTS	Back Cover
RECYCLING INFORMATION	Back Cover

WARNING DECAL PLACEMENT

This drawing shows the location(s) of the warning decal(s). **If a decal is missing or illegible, see the front cover of this manual and request a free replacement decal. Apply the decal in the location shown.** Note: The decal(s) may not be shown at actual size.

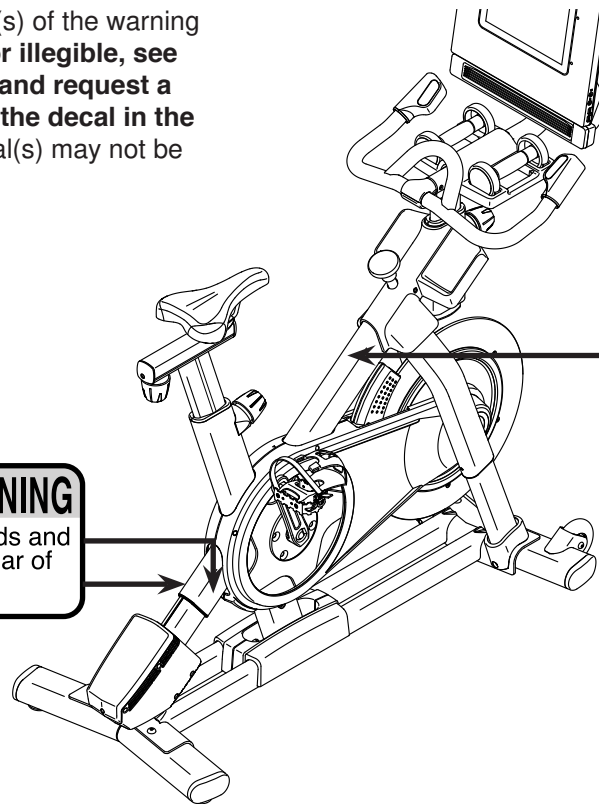

⚠ WARNING

- Misuse of this bike may result in serious injury.
- Read user's manual prior to use and follow all warnings and instructions.
- Do not allow children on or around bike.
- Pedals continue to spin when you stop pedaling.
- Spinning pedals can cause injury.
- Reduce pedal speed in a controlled manner.
- Max user weight: 330 lbs/150kg.
- Always use this bike on a level surface.
- This bike is not intended for therapeutic use.
- For safety, lock the bike when it is not in use.
- Replace label if damaged, illegible or removed.

NORDICTRACK and IFIT are registered trademarks of ICON Health & Fitness, Inc. The Bluetooth® word mark and logos are registered trademarks of Bluetooth SIG, Inc. and are used under license. Google Maps is a trademark of Google LLC. Wi-Fi is a registered trademark of Wi-Fi Alliance. WPA and WPA2 are trademarks of Wi-Fi Alliance.

IMPORTANT PRECAUTIONS

⚠️ WARNING: To reduce the risk of burns, fire, electric shock, or injury to persons, read all important precautions and instructions in this manual and all warnings on your studio cycle before using your studio cycle. ICON assumes no responsibility for personal injury or property damage sustained by or through the use of this product.

1. It is the responsibility of the owner to ensure that all users of the studio cycle are adequately informed of all precautions.
2. Before beginning any exercise program, consult your physician. This is especially important for persons over age 35 or persons with pre-existing health problems.
3. The studio cycle is not intended for use by persons with reduced physical, sensory, or mental capabilities or lack of experience and knowledge, unless they are given supervision or instruction about use of the studio cycle by someone responsible for their safety.
4. Use the studio cycle only as described in this manual.
5. The studio cycle is intended for home use only. Do not use the studio cycle in a commercial, rental, or institutional setting.
6. Keep the studio cycle indoors, away from moisture and dust. Do not put the studio cycle in a garage or covered patio, or near water.
7. Place the studio cycle on a level surface with at least 2 ft. (0.6 m) of clearance around the studio cycle. To protect the floor or carpet from damage, place a mat under the studio cycle.
8. Inspect and properly tighten all parts each time the studio cycle is used. Replace any worn parts immediately.
9. Keep children under age 13 and pets away from the studio cycle at all times.
10. When connecting the power cord (see page 15), plug the power cord into a grounded circuit.
11. Do not modify the power cord or use an adapter to connect the power cord to an improper receptacle. Keep the power cord away from heated surfaces. Do not use an extension cord.
12. Do not operate the studio cycle if the power cord or plug is damaged, or if the studio cycle is not working properly.
13. **DANGER:** Always unplug the power cord and press the power switch to the off position when the studio cycle is not in use and before cleaning the studio cycle. Servicing other than the procedures in this manual should be performed by an authorized service representative only.
14. Wear appropriate clothes while exercising; do not wear loose clothes that could become caught on the studio cycle. Always wear athletic shoes for foot protection.

15. The studio cycle should not be used by persons weighing more than 330 lbs. (150 kg).

16. Be careful when mounting and dismounting the studio cycle.

17. Always keep your back straight while using the studio cycle; do not arch your back.

18. The studio cycle does not have a freewheel; the pedals will continue to move until the flywheel stops. Reduce your pedaling speed in a controlled way.

19. To stop the flywheel quickly, press the brake knob downward.

20. When the studio cycle is not in use, press the brake knob downward and tighten it firmly.

21. Over exercising may result in serious injury or death. If you feel faint, if you become short of breath, or if you experience pain while exercising, stop immediately and cool down.

SAVE THESE INSTRUCTIONS

BEFORE YOU BEGIN

Congratulations for selecting the revolutionary NORDICTRACK® COMMERCIAL S10I STUDIO CYCLE. The COMMERCIAL S10I STUDIO CYCLE is unlike any ordinary exercise bike. With full adjustability, an interactive wireless touchscreen console, an incline system that simulates real-world terrain, and an array of other features, the COMMERCIAL S10I STUDIO CYCLE provides an immersive in-home studio cycling experience.

For your benefit, read this manual carefully before you use the studio cycle. If you have questions after reading this manual, please see the front cover of this manual. To help us assist you, note the product model number and serial number before contacting us. The model number and the location of the serial number decal are shown on the front cover of this manual.

Before reading further, please familiarize yourself with the parts that are labeled in the drawing below.

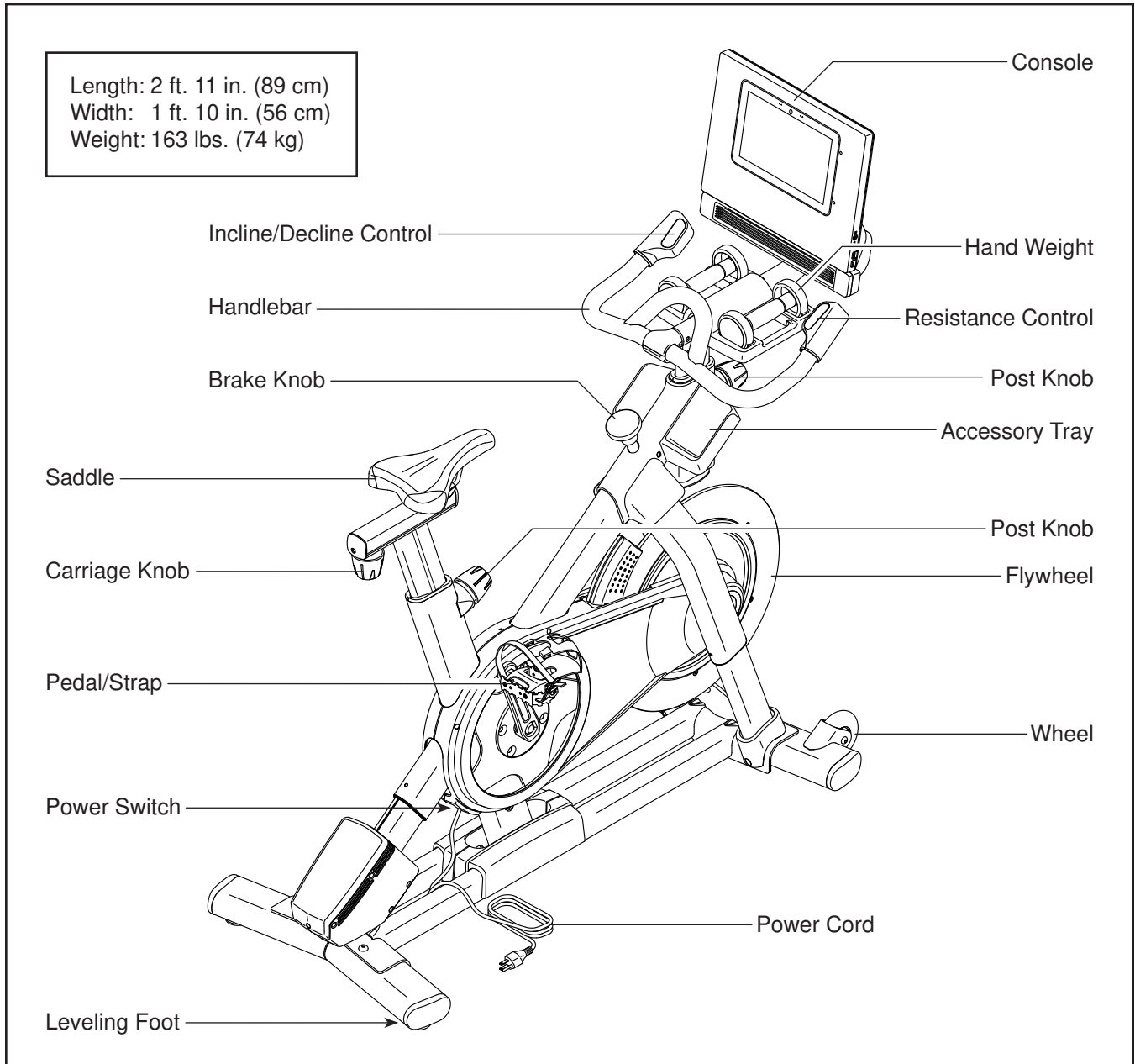

PART IDENTIFICATION CHART

Use the drawings below to identify the small parts needed for assembly. The number in parentheses below each drawing is the key number of the part, from the PART LIST near the end of this manual. The number following the key number is the quantity needed for assembly. **Note: If a part is not in the hardware kit, check to see if it has been preassembled. Extra parts may be included.**

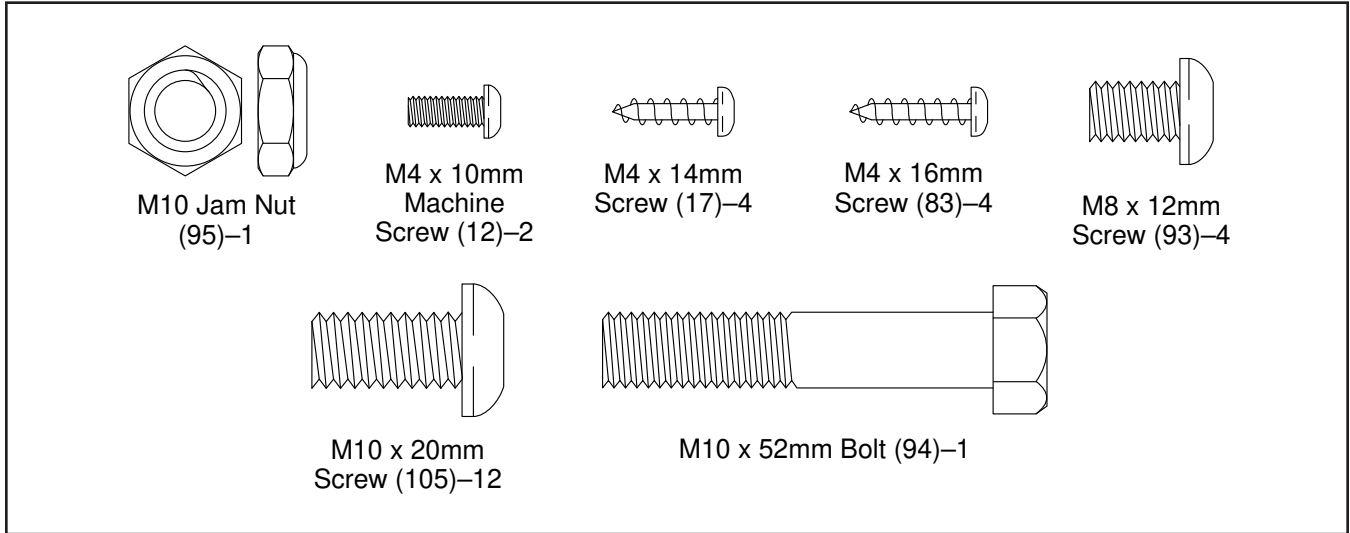

ASSEMBLY

- Assembly requires two persons.
- Place all parts in a cleared area and remove the packing materials. Do not dispose of the packing materials until you complete all assembly steps.
- To identify small parts, see page 6.
- To avoid damaging parts, do not use power tools.

- In addition to the included tool(s), assembly requires the following tool(s):

one Phillips screwdriver 

one adjustable wrench 

one rubber mallet 

Assembly may be easier if you have a set of wrenches.

1. **To register your product and activate your warranty in the UK**, go to iconsupport.eu. If you do not have internet access, call Customer Service (see the front cover of this manual).

To register your product and activate your warranty in Australia, email or post the following information to the email address or postal address on the front cover of this manual.

- your receipt (make sure to keep a copy)
- your name, address, and telephone number
- the model number, serial number, and name of your product (see the front cover of this manual)

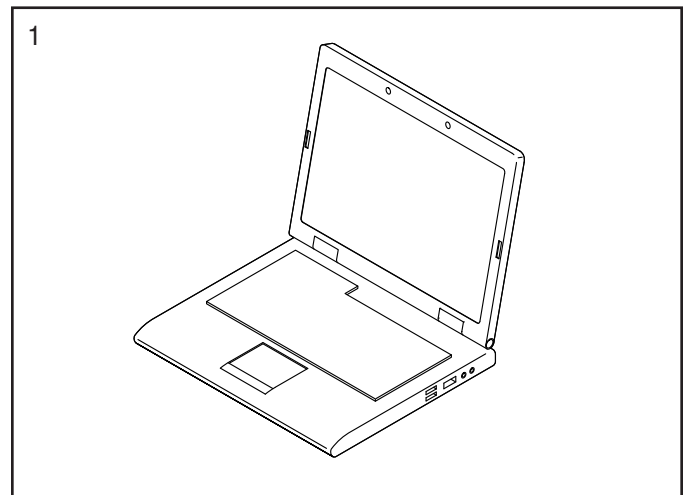

2. Attach the Front Stabilizer (3) to the Base (2) with four M10 x 20mm Screws (105); **do not fully tighten the Screws yet.**

See the inset drawing. Finish attaching the Front Stabilizer (3) with two additional M10 x 20mm Screws (105).

Then, fully tighten all six M10 x 20mm Screws (105).

See the inset drawing. Press the right Leg Cover (64) downward and attach it to the Base (2) with an M4 x 10mm Machine Screw (12).

Attach the other Leg Cover (not shown) in the same way.

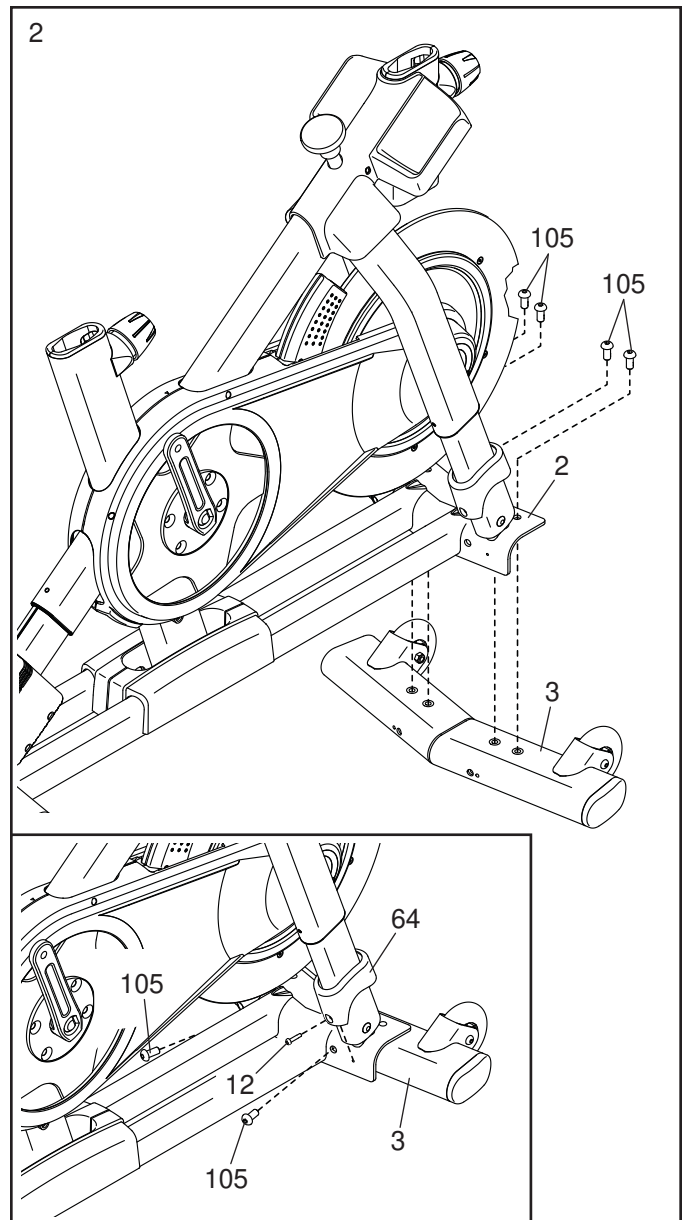

3. Attach the Rear Stabilizer (4) to the Base (2) with four M10 x 20mm Screws (105); **do not fully tighten the Screws yet.**

See the inset drawing. Finish attaching the Rear Stabilizer (4) with two additional M10 x 20mm Screws (105).

Then, fully tighten all six M10 x 20mm Screws (105).

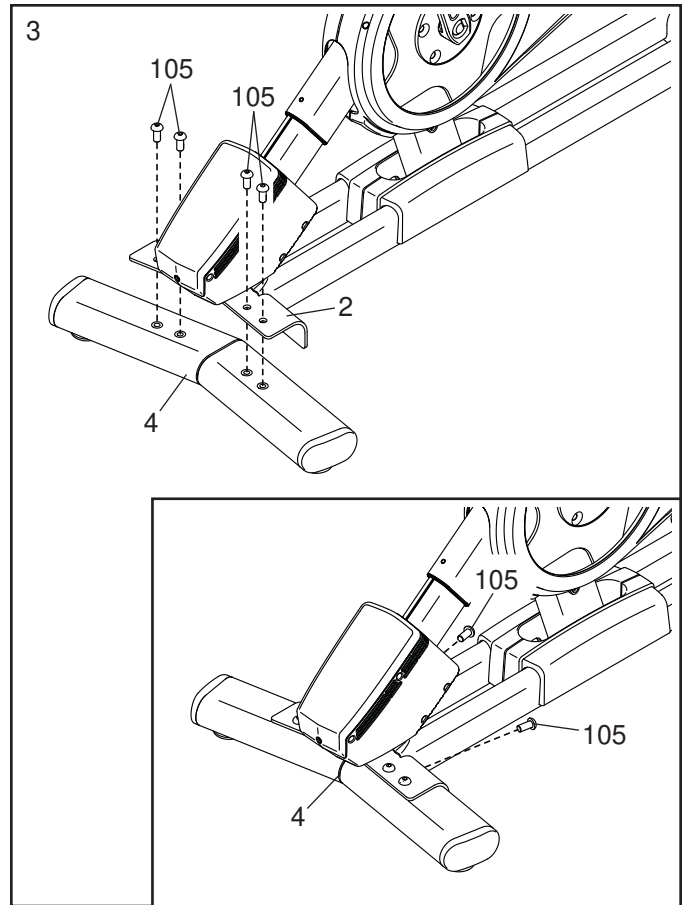

4. **See the inset drawing.** Orient the Handlebar Post (7) so that the lower slot (A) is on the side shown.

Next, loosen the indicated Post Knob (100) and insert the Handlebar Post (7) into the Frame (1) until the lower end of the Handlebar Post is below the Frame. Then, tighten the Post Knob.

Then, insert the end of the Lower Wire (122) into the Frame (1) and the Handlebar Post (7) and pull it out of the upper slot (B) in the Handlebar Post as shown by the dashed line at the right.

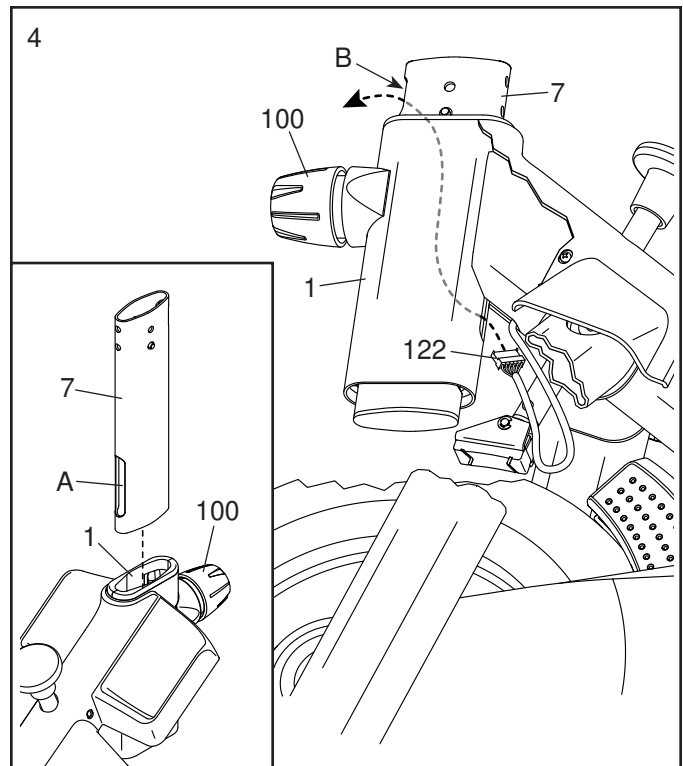

5. Insert the Handlebar (97) into the Handlebar Post (7). Attach the Handlebar with four M8 x 12mm Screws (93); **start all the Screws, and then tighten them.**

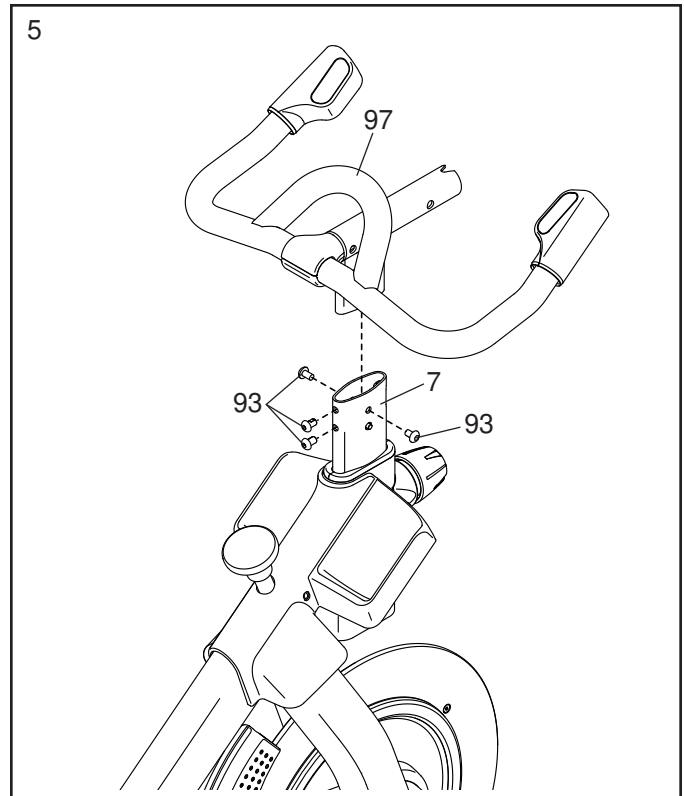

6. **Tip: Avoid pinching the wires (C).** Slide the Console Support (8) onto the Handlebar (97).

Attach the Console Support (8) with an M10 x 52mm Bolt (94) and an M10 Jam Nut (95); **make sure that the Jam Nut is in the hexagonal hole (D).** Do not fully tighten the Bolt yet.

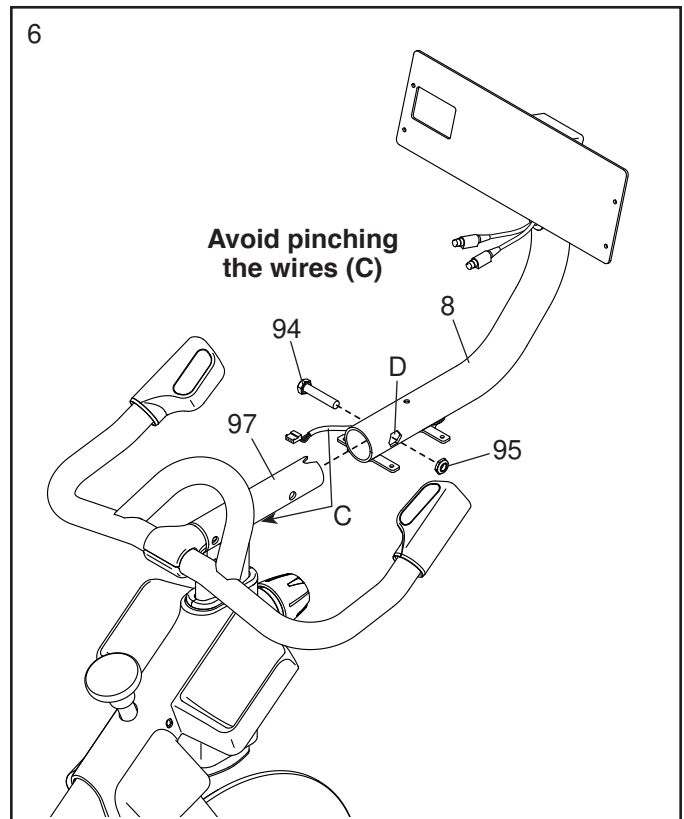

7. Look under the Console Support (8) and identify the Upper Wire (123), which has a larger connector than the Extension Wire (124).

Connect the Upper Wire (123) to the Lower Wire (122) extending from the Handlebar Post (7). Then, insert the connectors on both Wires into the Handlebar Post.

Next, connect the Extension Wire (124) to the Control Wire (125) extending from the Handlebar (97). Then, insert the connectors on both Wires into the Handlebar.

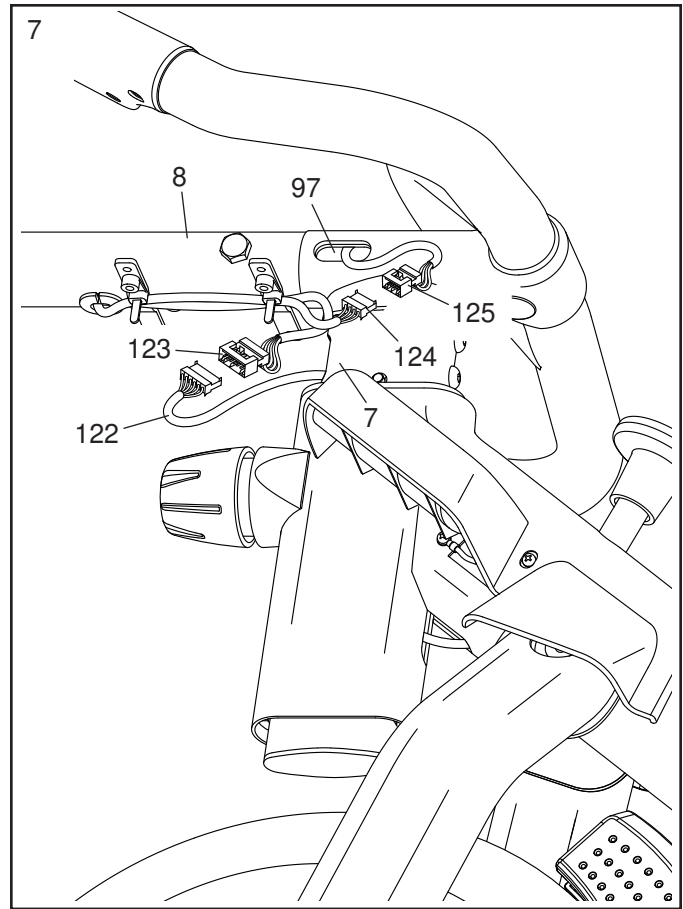

8. Have a second person hold the Console (10) near the Console Bracket (11).

Plug the Upper Wire (123) and the Extension Wire (124) into the receptacles on the back of the Console (10); **make sure to plug the Wire marked with red into the receptacle marked with red, and plug the Wire marked with yellow into the receptacle marked with yellow.**

Tip: Avoid pinching the wires. If necessary, tilt the Console Bracket (11) upward to make this step easier. Attach the Console (10) to the Console Bracket with four M4 x 16mm Screws (83); **start all the Screws, and then tighten them.**

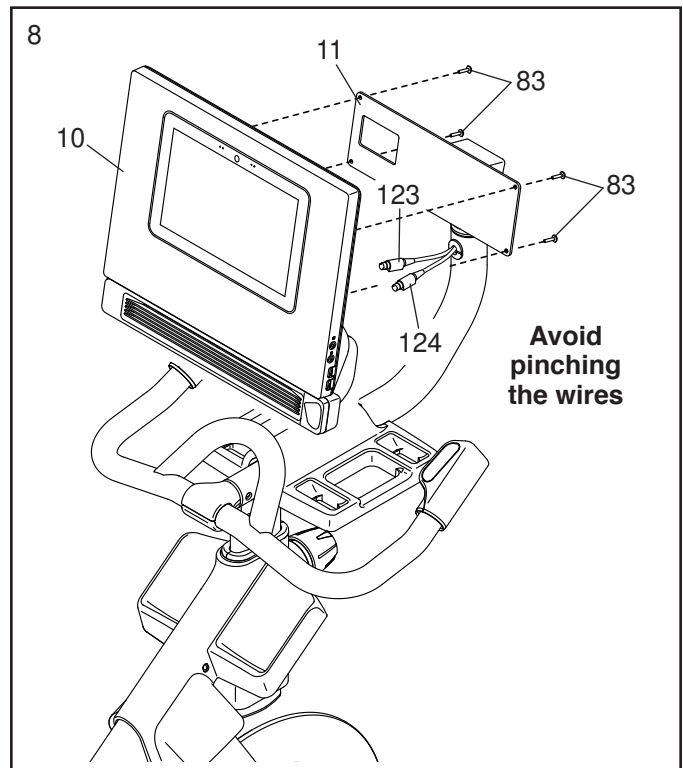

9. **IMPORTANT:** Have a second person move the Console (10) to a level position. While the second person holds the Console steady, tighten the M10 x 52mm Bolt (94).

Next, orient the Hand Weight Tray (38) so that the largest opening (E) is facing forward.

Tip: Avoid pinching the wires (C). Attach the Hand Weight Tray (38) to the Console Support (8) with four M4 x 14mm Screws (17); **start all the Screws, and then tighten them.**

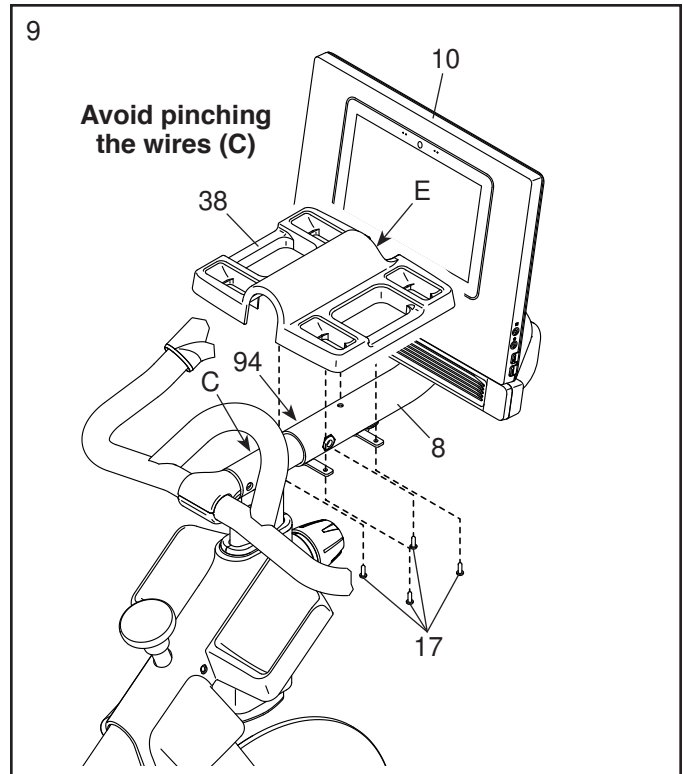

10. Orient the Saddle Post (13) as shown.

Loosen the indicated Post Knob (100). Next, insert the Saddle Post (13) into the Frame (1), and slide the Saddle Post to the desired height. Then, tighten the Post Knob.

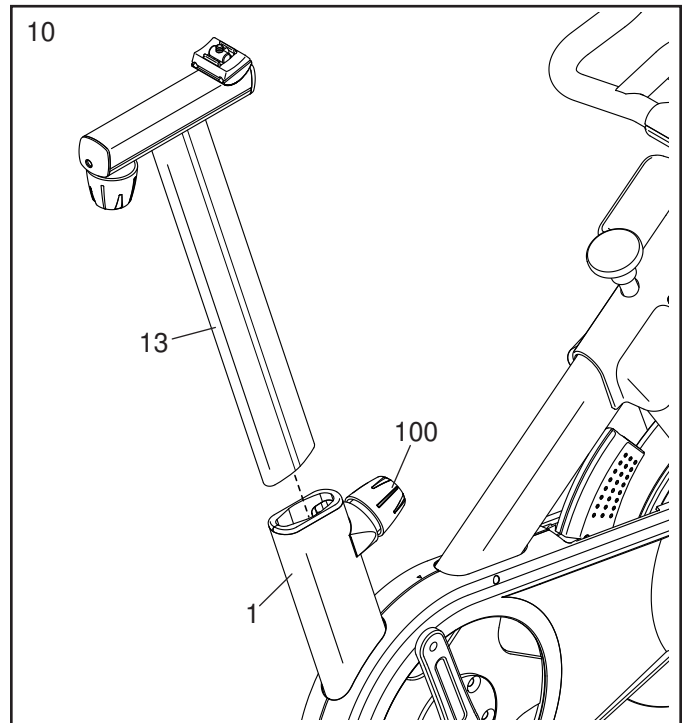

11. **Note: You can attach your own saddle if desired.**

See inset drawing a. Tip the Saddle (54) to one side and slide one of the rails (F) as far as possible between the Lower Saddle Clamp (52) and the Upper Saddle Clamp (53). If necessary, further loosen the M8 Saddle Screw (41).

See inset drawing b. Tip the Saddle (54) downward as shown and slide the other rail (F) between the Saddle Clamps (52, 53). **Make sure that both rails are in the grooves in the Saddle Clamps and that the Saddle is straight and level.** Then, firmly tighten the Saddle Screw (41).

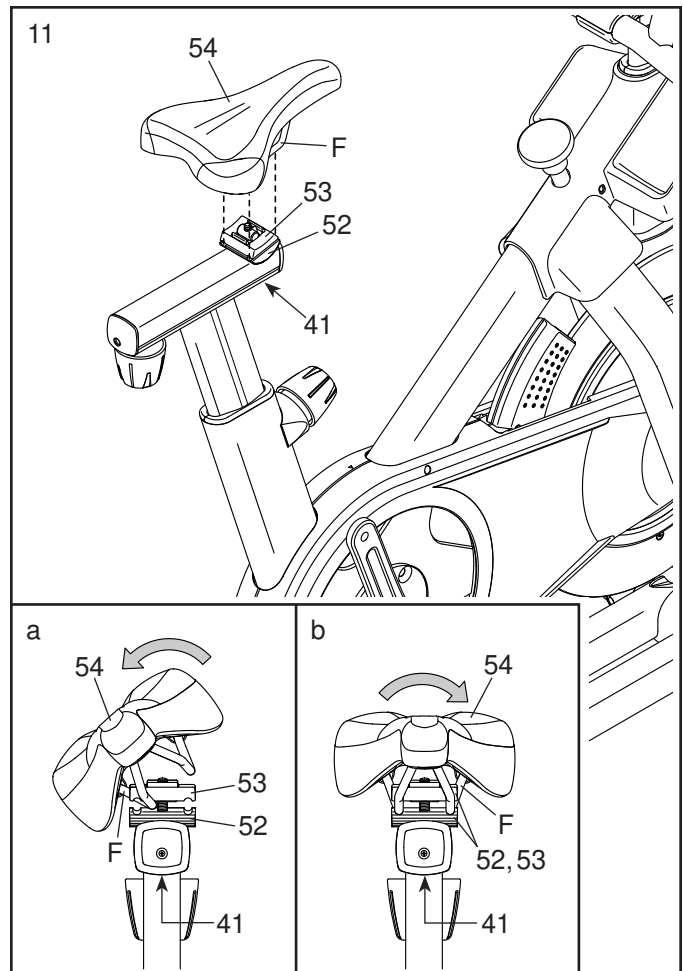

12. **Note: You can attach your own pedals if desired.**

Identify the right Pedal (56). Using an adjustable wrench or the included tool, **firmly tighten** the right Pedal **clockwise** into the Right Crank Arm (19).

Firmly tighten the left Pedal (not shown) counterclockwise into the Left Crank Arm (not shown). IMPORTANT: You must turn the left Pedal counterclockwise to attach it.

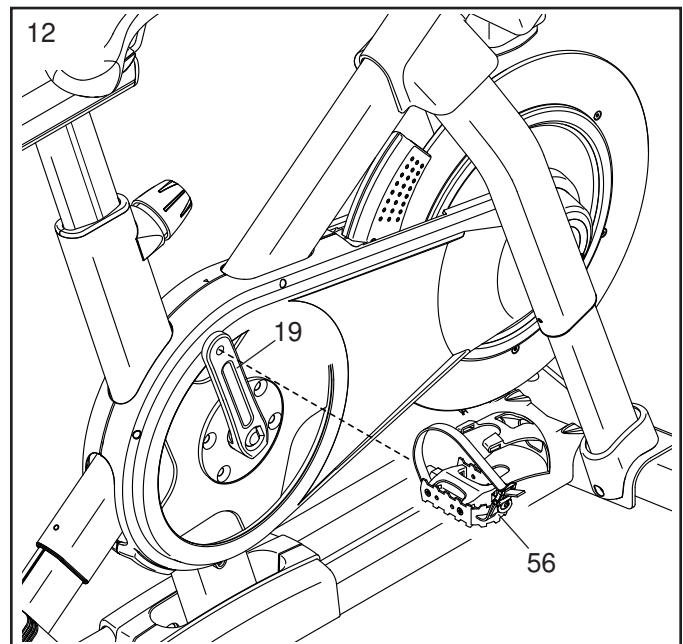

13. Set the two Hand Weights (14) in the Hand Weight Tray (38).

IMPORTANT: Make sure not to hit the Console (10) with the Hand Weights (14) when you set the Hand Weights in the Hand Weight Tray (38) after each use.

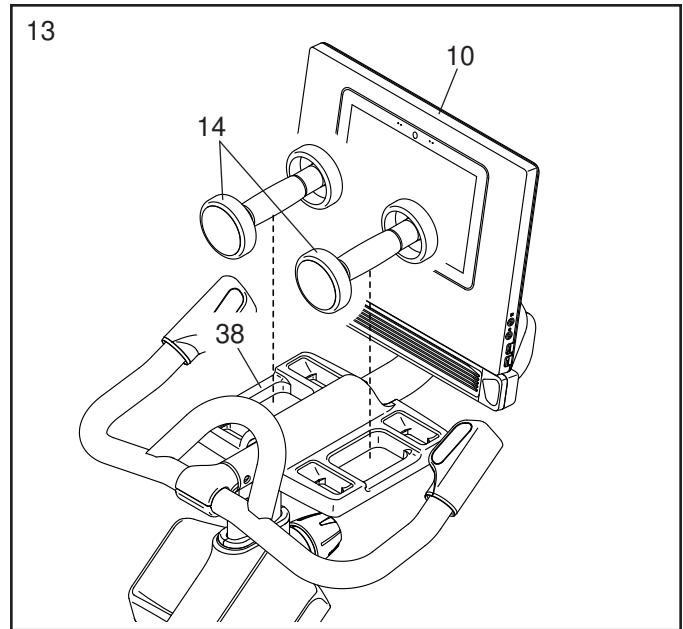

14. Plug the appropriate Power Cord (120) into the socket on the Frame (1).

Next, route the Power Cord (120) through the two Anchored Zip Ties (55) on the Base (2) as shown. Then, pull the Anchored Zip Ties closed.

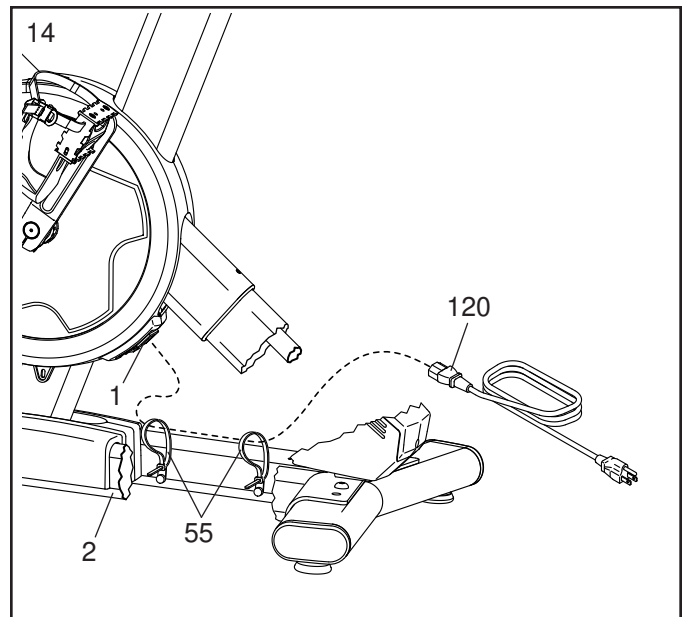

15. **After the studio cycle is assembled, inspect it to make sure that it is assembled correctly and that it functions properly. Make sure that all parts are properly tightened before you use the studio cycle.** Extra parts may be included. Place a mat beneath the studio cycle to protect the floor.

HOW TO USE THE STUDIO CYCLE

HOW TO PLUG IN THE POWER CORD

This product must be earthed. If it should malfunction or break down, earthing provides a path of least resistance for electric current to reduce the risk of electric shock. This product's power cord has an equipment-earthing conductor and an earthing plug. **IMPORTANT: If the power cord is damaged, it must be replaced with a manufacturer-recommended power cord.**

⚠ DANGER: Improper connection of the equipment-earthing conductor can result in an increased risk of electric shock. Check with a qualified electrician or serviceman if you are in doubt as to whether the product is properly earthed. Do not modify the plug provided with the product—if it will not fit the outlet, have a proper outlet installed by a qualified electrician

Follow the steps below to plug in the power cord.

1. Plug the indicated end of the power cord into the socket on the frame.

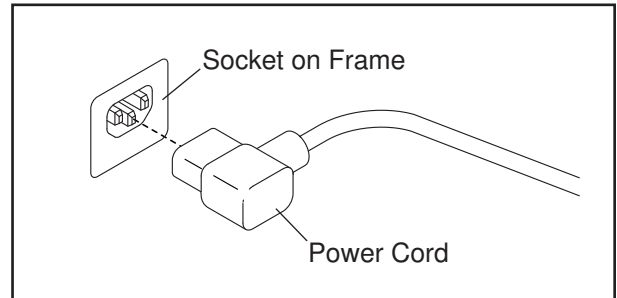

2. Plug the power cord into an appropriate outlet that is properly installed and earthed in accordance with all local codes and ordinances.

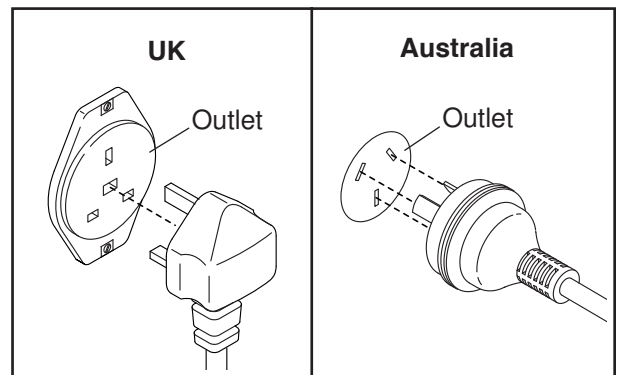

FEATURES OF THE STUDIO CYCLE

Measuring Watts

Each studio cycle is calibrated to measure your power output and to allow you to monitor your watts and RPMs directly on the console.

By monitoring your watts and RPMs, you can see how hard you are training and make sure that you are challenging yourself and improving.

The Incline System

The studio cycle can incline and decline to realistically simulate outdoor terrain. When you use or create map workouts of training routes with iFit® (see the console instructions beginning on page 19 for more information), the studio cycle will automatically incline and decline to match the real-world terrain.

Interactive Wireless Touchscreen Console

The wireless touchscreen console works with iFit to provide an interactive and immersive in-home studio experience that allows you to participate virtually in group studio classes led by personal trainers and to experience workouts around the world.

HOW TO ADJUST THE GEOMETRY OF THE STUDIO CYCLE

The studio cycle can be adjusted to match the geometry of your road bike to promote correct form and to ensure proper training of the muscles. **Make adjustments in small increments, and then pedal the studio cycle to test the adjustments.**

How to Adjust the Angle of the Saddle

You can adjust the angle of the saddle to the position that is most comfortable. You can also adjust the saddle forward or backward for increased comfort or to adjust the distance to the handlebar.

To adjust the saddle, first loosen the saddle screw (A) in the carriage a few turns. Next, tilt the saddle upward or downward or slide the saddle forward or backward to the desired position.

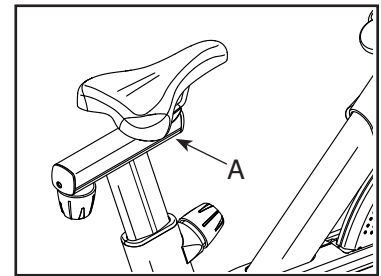

Then, retighten the saddle screw.

Note: You can remove the saddle and attach your own saddle to the studio cycle if desired.

How to Adjust the Saddle Carriage

To adjust the position of the carriage, loosen the carriage knob (B), move the saddle carriage forward or backward to the desired position, and then firmly tighten the carriage knob.

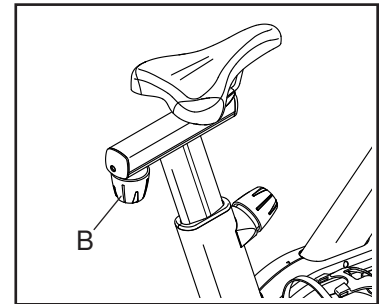

How to Adjust the Saddle Post

For effective training, the saddle should be at the proper height. As you pedal, there should be a slight bend in your knees when the pedals are in the lowest position.

To adjust the saddle post, loosen the post knob (C), move the saddle post upward or downward, and then firmly tighten the post knob.

IMPORTANT: Do not raise the saddle post beyond the “MAX” mark on the saddle post.

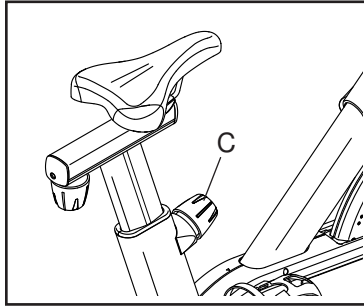

How to Adjust the Position of the Console

The console (E) can be adjusted upward, downward, or to the side. To adjust the position of the console, simply hold the sides of the console and press it to the desired position. You can pivot the console all the way to the side so that you can view it while standing next to the studio cycle to perform hand weight exercises or other floor exercises.

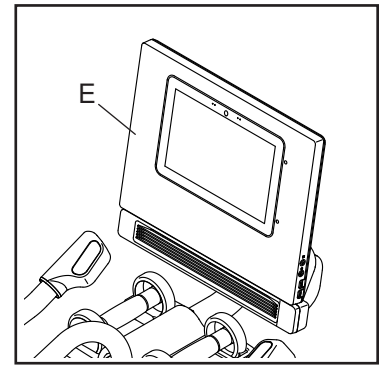

HOW TO LEVEL THE STUDIO CYCLE

If the studio cycle rocks slightly on your floor during use, turn one or both of the leveling feet (F) beneath the rear stabilizer until the rocking motion is eliminated.

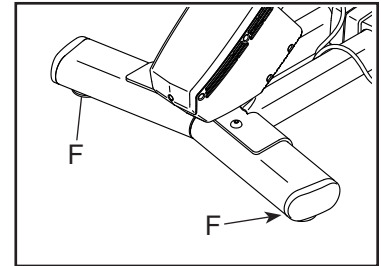

How to Adjust the Handlebar Post

To adjust the handlebar post, loosen the post knob (D), move the handlebar post upward or downward, and then firmly tighten the post knob.

IMPORTANT: Do not raise the handlebar post beyond the “MAX” mark on the handlebar post.

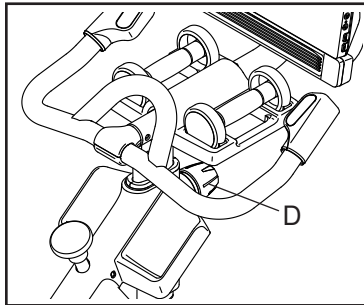

HOW TO USE THE PEDALS

To use the pedals, insert your shoes into the toe cages and pull the ends of the toe straps. To adjust the toe straps, press and hold the tabs (G) on the buckles, adjust the toe straps to the desired position, and then release the tabs.

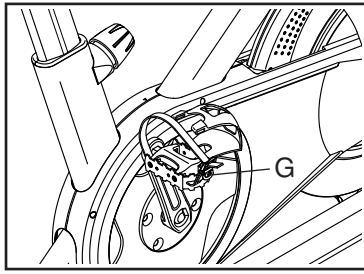

Note: You can remove the pedals and attach your own pedals to the studio cycle if desired.

HOW TO USE THE BRAKE KNOB

To change the resistance of the pedals, press the buttons on the right handlebar (see step 3 on page 22). **To stop the flywheel, press the brake knob (H) downward.** The flywheel will quickly come to a complete stop.

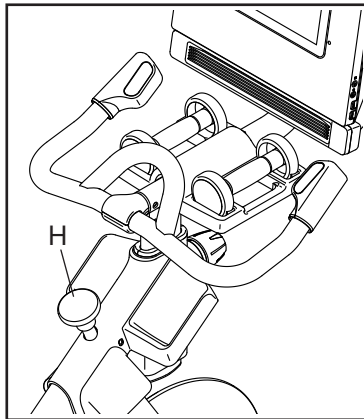

HOW TO LOCK THE STUDIO CYCLE

IMPORTANT: Lock the studio cycle when it is not in use. To lock the studio cycle, press the brake knob (H) downward and tighten it firmly. This will lock the studio cycle so that the flywheel cannot turn. To unlock the studio cycle, loosen the brake knob.

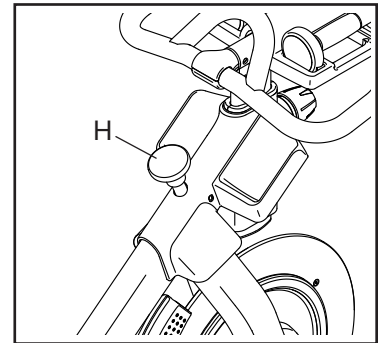

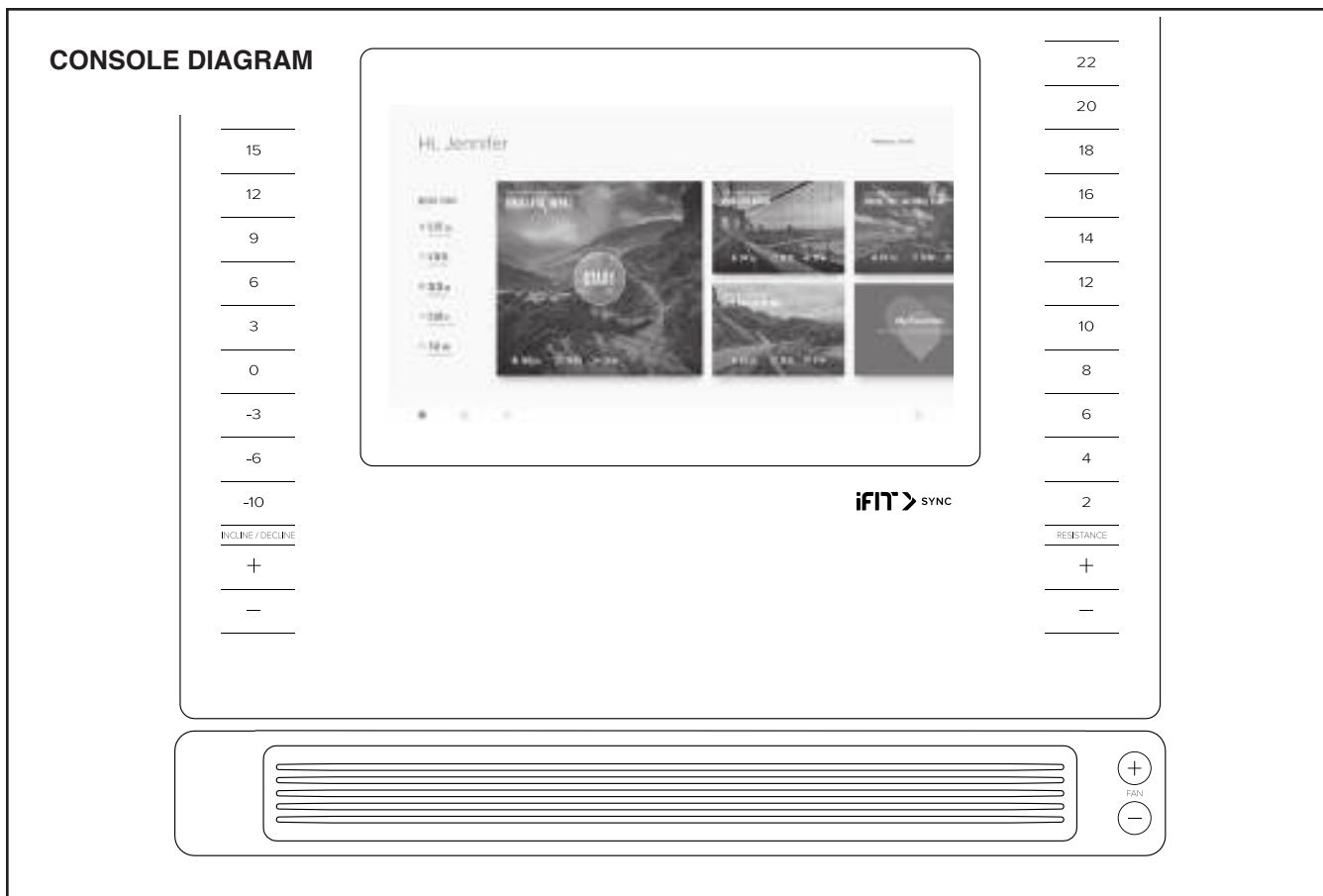

FEATURES OF THE CONSOLE

The advanced console offers an array of features designed to make your workouts more effective and enjoyable.

The console features wireless technology that enables the console to connect to iFit. With iFit, you can access a large and varied workout library, create your own workouts, track your workout results, and access many other features.

In addition, the console features a selection of onboard workouts. Each workout automatically controls the resistance of the pedals and the incline of the frame as it guides you through an effective exercise session.

When you use the manual mode of the console, you can change the resistance of the pedals and the incline of the frame with the touch of a button.

While you exercise, the console will display continuous exercise feedback. You can also measure your heart rate using an optional chest heart rate monitor (see page 29 for more information).

You can also listen to your favorite workout music or audio books with the console sound system while you exercise.

To turn on the power, see page 20. **To learn how to use the touch screen**, see page 20. **To set up the console**, see page 21.

HOW TO TURN ON THE POWER

IMPORTANT: If the studio cycle has been exposed to cold temperatures, allow it to warm to room temperature before you turn on the power. If you do not do this, you may damage the console or other electrical components.

Plug in the power cord (see HOW TO PLUG IN THE POWER CORD on page 15). Next, locate the power switch on the frame near the power cord. Press the power switch to the reset position (A).

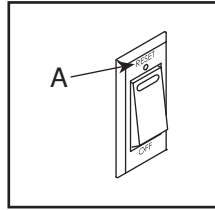

The console will then turn on and be ready for use.

Note: When you turn on the power for the first time, the incline system may calibrate automatically. The frame will move upward and downward as it calibrates. When the frame stops moving, the incline system is calibrated.

IMPORTANT: If the incline system does not calibrate automatically, see step 6 on page 21 and manually calibrate the incline system.

HOW TO USE THE TOUCH SCREEN

The console features a tablet with a full-color touch screen. The following information will help you use the touch screen:

- The console functions similarly to other tablets. You can slide or flick your finger against the screen to move certain images on the screen, such as the displays in a workout.
- To type information into a text box, first touch the text box to view the keyboard. To use numbers or other characters on the keyboard, touch *?123*. To view more characters, touch *Alt*. Touch *Alt* again to return to the number keyboard. To return to the letter keyboard, touch *ABC*. To use a capital character, touch the shift button (upward-facing arrow symbol). To use multiple capital characters, touch the shift button again. To return to the lowercase keyboard, touch the shift button a third time. To clear the last character, touch the clear button (backward-facing arrow with an X symbol).

HOW TO SET UP THE CONSOLE

Before you use the studio cycle for the first time, set up the console.

1. Connect to your wireless network.

To use iFit workouts and to use several other features of the console, the console must be connected to a wireless network. Follow the prompts on the screen to connect the console to your wireless network.

2. Customize settings.

Follow the prompts on the screen to set the desired unit of measurement and your time zone.

Note: To change these settings later, see HOW TO CHANGE CONSOLE SETTINGS on page 26.

3. Log into or create an iFit account.

Follow the prompts on the screen to log into your iFit account or to create an iFit account.

4. Tour the console.

The first time you use the console, a tour presentation will guide you through the features of the console. Note: To view the tour presentation again at any time, touch the profile button (person symbol) on the screen, touch *Settings*, and then touch *How It Works*.

5. Check for firmware updates.

First, touch the profile button, touch *Settings*, touch *Maintenance*, and then touch *Update*. The console will check for firmware updates. For more information, see HOW TO CHANGE CONSOLE SETTINGS on page 26.

6. Calibrate the incline system.

First, touch the profile button, touch *Settings*, touch *Maintenance*, and then touch *Calibrate Incline*. The frame will rise and lower as it calibrates. For more information, see HOW TO CHANGE CONSOLE SETTINGS on page 26.

The console is now ready for you to begin working out. The following pages explain the workouts and other features that the console offers.

To use the manual mode, see this page. **To use a map workout or an onboard workout**, see page 23. **To create a draw-your-own-map workout**, see page 24. **To use an iFit workout**, see page 25.

To change console settings, see page 26. **To connect to a wireless network**, see page 28. **To use the sound system**, see page 28. **To connect an HDMI cable**, see page 29.

Note: If there is a sheet of plastic on the screen, remove the plastic.

HOW TO USE THE MANUAL MODE

1. Touch the screen or press any button on the console to turn on the console.

See HOW TO TURN ON THE POWER on page 20. Note: It may take a few moments for the console to be ready for use.

2. Select the main menu.

When you turn on the console, the main menu will appear on the screen after the console boots up.

If you are in a workout, touch the screen, touch *Pause*, touch *End*, and then touch *Finish* to return to the main menu. If you are in the settings menus, touch the back button (arrow symbol) and then touch the close button (x symbol) to return to the main menu.

3. Change the resistance of the pedals and the incline of the frame as desired.

Touch *Manual Start* and begin pedaling.

You can change the resistance of the pedals by pressing the numbered Resistance buttons on the console, by pressing the Resistance increase and decrease buttons on the console, or by pressing the Resistance increase and decrease buttons on the right handlebar.

You can also change the incline of the frame by pressing the numbered Incline/Decline buttons on the console, by pressing the Incline/Decline increase and decrease buttons on the console, or by pressing the Incline/Decline increase and decrease buttons on the left handlebar.

Note: After you press a button, it will take a moment for the pedals to reach the selected resistance level or for the frame to reach the selected incline level.

4. Follow your progress.

The console offers several display modes. The display mode that you select will determine which workout information is shown.

To select the desired display mode or to view statistics and charts, drag downward on the screen. You can also touch the more button (+ symbol) to view statistics or charts.

If desired, adjust the volume level by pressing the volume increase and decrease buttons on the right side of the console.

To pause the workout, simply touch the screen or stop pedaling. To continue the workout, simply resume pedaling.

To end the workout session, first touch the screen to pause the workout. Next, touch *End*; a workout summary will appear on the screen. If desired, you can publish your results using one of the options on the screen. Then, touch *Finish* to return to the main menu.

5. Wear a heart rate monitor and measure your heart rate if desired.

You can wear an optional heart rate monitor to measure your heart rate. For more information about the optional heart rate monitor, see page 29. Note: The console is compatible with Bluetooth® Smart heart rate monitors.

When your heartbeat is detected, your heart rate will be shown.

6. Turn on the fan if desired.

The fan has several speed settings, including an auto mode. While the auto mode is selected, the speed of the fan will automatically increase or decrease as your pedaling speed increases or decreases. Press the Fan increase and decrease buttons repeatedly to select a fan speed or to turn off the fan.

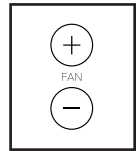

Note: If the pedals are not moved for a while when the main menu is selected, the fan will turn off automatically.

7. When you are finished exercising, unplug the power cord.

When you are finished exercising, press the power switch to the off position and unplug the power cord. **IMPORTANT: If you do not do this, the electrical components of the studio cycle may wear prematurely.**

HOW TO USE A MAP WORKOUT OR AN ONBOARD WORKOUT

1. Touch the screen or press any button on the console to turn on the console.

See HOW TO TURN ON THE POWER on page 20. Note: It may take a few moments for the console to be ready for use.

2. Select the main menu or the workout library.

When you turn on the console, the main menu will appear on the screen after the console boots up.

If you are in a workout, touch the screen, touch *Pause*, touch *End*, and then touch *Finish* to return to the main menu. If you are in the settings menus, touch the back button (arrow symbol) and then touch the close button (x symbol) to return to the main menu.

Touch the buttons at the bottom of the screen to select either the main menu or the workout library.

3. Select a workout.

To select a workout from the main menu or the workout library, simply touch the desired workout button on the screen. Slide or flick the screen to scroll upward or downward if necessary.

Note: To use a map workout, the console must be connected to a wireless network (see HOW TO CONNECT TO A WIRELESS NETWORK on page 28).

The featured map workouts on your console will change periodically. To save one of the featured map workouts for future use, you can add it as a favorite by touching the favorites button (heart symbol). You must be logged into your iFit account to save a featured map workout (see step 3 on page 25).

To draw your own map for a workout, see HOW TO CREATE A DRAW-YOUR-OWN-MAP WORKOUT on page 24.

When you select a workout, the screen will show an overview of the workout that includes details such as the duration and distance of the workout and the approximate number of calories you will burn during the workout.

4. Start the workout.

Touch *Start* to start the workout.

During some workouts, the screen will show a map of the route and a marker indicating your progress. Touch the buttons on the screen to select the desired map options.

The display modes will also show your progress. To select the desired display mode or to view statistics and charts, swipe downward on the screen. You can also touch the more button (+ symbol) to view statistics or charts.

The workout will function in the same way as the manual mode (see page 21).

During some workouts, the screen may show a target speed. As you exercise, keep your pedaling speed near the target speed shown on the screen. A message may appear prompting you to increase, decrease, or maintain your pedaling speed.

IMPORTANT: The target speed is intended only to provide motivation. Your actual pedaling speed may be slower than the target speed. Make sure to pedal at a speed that is comfortable for you.

If the resistance level and/or incline level is too high or too low, you can manually override the setting by pressing the Resistance buttons or the Incline/Decline buttons. **If you press a Resistance button**, you can then manually control the resistance level (see step 3 on page 22). **If you press an Incline/Decline button**, you can then manually control the incline level (see step 3 on page 22). **To return to the programmed resistance and/or incline settings of the workout**, touch *Follow Workout*.

Note: The calorie goal shown in the workout description is an estimate of the number of calories that you will burn during the workout. The actual number of calories that you burn will depend on various factors, such as your weight. In addition, if you manually change the resistance level or incline level of the frame during the workout, the number of calories you burn will be affected.

To pause the workout, simply touch the screen or stop pedaling. To end the workout, touch *End*. To continue the workout, simply resume pedaling.

When the workout comes to an end, a workout summary will appear on the screen. If desired, you can publish your results using one of the options on the screen. Then, touch *Finish* to return to the main menu.

5. Follow your progress.

See step 4 on page 22.

6. Wear a heart rate monitor and measure your heart rate if desired.

See step 5 on page 22.

7. Turn on the fan if desired.

See step 6 on page 22.

8. When you are finished exercising, unplug the power cord.

See step 7 on page 22.

HOW TO CREATE A DRAW-YOUR-OWN-MAP WORKOUT

1. Touch the screen or press any button on the console to turn on the console.

See HOW TO TURN ON THE POWER on page 20. Note: It may take a few moments for the console to be ready for use.

2. Select a draw-your-own-map workout.

When you turn on the console, the main menu will appear on the screen after the console boots up.

If you are in a workout, touch the screen, touch *Pause*, touch *End*, and then touch *Finish* to return to the main menu. If you are in the settings menus, touch the back button (arrow symbol) and then touch the close button (x symbol) to return to the main menu.

To select a draw-your-own-map workout, touch the draw-your-own-map button (map symbol) at the bottom of the screen.

3. Draw your map.

Navigate to the area on the map where you want to draw your workout by sliding your fingers on the screen. Touch the screen to add the start point for your workout. Then, touch the screen to add the end point for your workout.

If you want to start and end your workout at the same point, touch *Loop* or *Out & Back* on the left side of the screen. You can also select whether you want your workout to snap to the road.

If you make a mistake, touch *Undo* on the left side of the screen.

The screen will display the elevation and distance statistics for your workout.

4. Save your workout.

Touch *Save New Workout* to save your workout. If desired, enter a title and description for your workout. Then, touch the continue button (> symbol).

5. Start the workout.

Touch *Start* to start the workout. The workout will function in the same way as a map workout or an onboard workout (see page 23).

6. Follow your progress.

See step 4 on page 22.

7. Wear a heart rate monitor and measure your heart rate if desired.

See step 5 on page 22.

8. Turn on the fan if desired.

See step 6 on page 22.

9. When you are finished exercising, unplug the power cord.

See step 7 on page 22.

HOW TO USE AN IFIT WORKOUT

To use an iFit workout, the console must be connected to a wireless network (see HOW TO CONNECT TO A WIRELESS NETWORK on page 28). An iFit account is also required.

1. Add workouts to your schedule on iFit.com.

On your computer, smartphone, tablet, or other device, open an internet browser, go to iFit.com, and log in to your iFit account.

Next, navigate to Menu > Library on the website. Browse the workout programs in the library and join the desired workouts.

Then, navigate to Menu > Schedule to view your schedule. All of the workouts that you have joined will appear on your schedule; you can arrange or delete the workouts on your schedule as desired.

Take time to explore the iFit.com website before you log out.

2. Select the main menu.

When you turn on the console, the main menu will appear on the screen after the console boots up.

If you are in a workout, touch the screen, touch *Pause*, touch *End*, and then touch *Finish* to return to the main menu. If you are in the settings menus, touch the back button (arrow symbol) and then touch the close button (x symbol) to return to the main menu.

3. Log in to your iFit account.

If you have not already done so, touch the profile button (person symbol) on the screen to log in to your iFit account. Follow the prompts on the screen to enter your username and password.

To switch users within your iFit account, touch the profile button, and then touch *Manage Accounts*. If more than one user is associated with the account, a list of users will appear. Touch the name of the desired user.

4. **Select an iFit workout that you have previously added to your schedule on iFit.com.**

IMPORTANT: Before iFit workouts will load, you must add them to your schedule on iFit.com (see step 1).

To load an iFit workout from iFit.com to the console, touch the calendar button (calendar symbol) at the bottom of the screen.

When you load a workout, the screen will show an overview of the workout that includes details such as the duration and distance of the workout and the approximate number of calories you will burn during the workout.

5. **Start the workout.**

Touch *Start* to start the workout. The workout will function in the same way as a map workout or an onboard workout (see page 23). Note: During a distance or time workout, the screen will not show a map.

6. **Follow your progress.**

See step 4 on page 22.

7. **Wear a heart rate monitor and measure your heart rate if desired.**

See step 5 on page 22.

8. **Turn on the fan if desired.**

See step 6 on page 22.

9. **When you are finished exercising, unplug the power cord.**

See step 7 on page 22.

For more information about iFit, go to iFit.com.

HOW TO CHANGE CONSOLE SETTINGS

IMPORTANT: Some of the settings and features described may not be enabled. Occasionally, a firmware update may cause your console to function slightly differently.

1. **Select the settings main menu.**

First, turn on the power (see HOW TO TURN ON THE POWER on page 20). Note: It may take a few moments for the console to be ready for use.

Next, select the main menu. When you turn on the console, the main menu will appear on the screen after the console boots up. If you are in a workout, touch the screen, touch *Pause*, touch *End*, and then touch *Finish* to return to the main menu.

Next, touch the profile button (person symbol) on the screen, and then touch *Settings*. The settings menu will appear on the screen.

2. **Navigate the settings menus and change settings as desired.**

Slide or flick the screen to scroll upward or downward if necessary. To view a settings menu, simply touch the menu name. To exit a menu, touch the back button (arrow symbol). You may be able to view and change settings in the following settings menus:

Account

- My Profile
- In Workout
- Manage Accounts

Equipment

- Equipment Info
- Equipment Settings
- Maintenance
- Wi-Fi

About

- How It Works
- Feedback
- Legal

3. View the console tour presentation.

To view a tour presentation that will guide you through the features of the console, touch *How It Works*.

4. Customize the unit of measurement and other settings.

To customize the unit of measurement, the time zone, or other settings, touch *Equipment Settings*, and then touch the desired settings.

The console can display speed and distance in either standard or metric units of measurement.

5. View machine information.

Touch *Equipment Info*, and then touch *Machine Info* to view information about your studio cycle.

6. Update the console firmware.

For the best results, regularly check for firmware updates. Touch *Maintenance*, and then touch *Update* to check for firmware updates using your wireless network. The update will begin automatically. **IMPORTANT: To avoid damaging the studio cycle, do not turn off the power while the firmware is being updated.**

The screen will show the progress of the update. When the update is complete, the studio cycle will turn off and then turn back on. If it does not, press the power switch into the off position. Wait for several seconds, and then press the power switch into the reset position. Note: It may take a few minutes for the console to be ready for use.

Note: Occasionally, a firmware update may cause the console to function slightly differently. These updates are always designed to improve your exercise experience.

7. Calibrate the incline system.

To calibrate the incline system, touch *Maintenance*, touch *Calibrate Incline*, and then touch *Begin*. The frame will automatically rise to the maximum incline level, lower to the minimum incline level, and then return to the starting position. This will calibrate the incline system. When the incline system is calibrated, touch *Finish*.

IMPORTANT: Keep pets, feet, and other objects away from the studio cycle while the incline system is calibrating.

8. Exit the settings main menu.

If you are in a settings menu, touch the back button. Then, touch the close button (x symbol) to exit the settings main menu.

HOW TO CONNECT TO A WIRELESS NETWORK

To use iFit workouts and to use several other features of the console, the console must be connected to a wireless network.

1. Select the main menu.

First, turn on the power (see HOW TO TURN ON THE POWER on page 20). Note: It may take a few moments for the console to be ready for use.

Next, select the main menu. When you turn on the console, the main menu will appear on the screen after the console boots up. If you are in a workout, touch the screen, touch *Pause*, touch *End*, and then touch *Finish* to return to the main menu.

2. Select the wireless network menu.

Touch the Wi-Fi button (wireless symbol) at the bottom of the screen to select the wireless network menu.

3. Enable Wi-Fi.

Make sure that Wi-Fi® is enabled. If it is not enabled, touch the *Wi-Fi* toggle to enable it.

4. Set up and manage a wireless network connection.

When Wi-Fi is enabled, the screen will show a list of available networks. Note: It may take a few moments for the list of wireless networks to appear.

Note: You must have your own wireless network and an 802.11b/g/n router with SSID broadcast enabled (hidden networks are not supported).

When a list of networks appears, touch the desired network. Note: You will need to know your network name (SSID). If your network has a password, you will also need to know the password.

Follow the prompts on the screen to enter your password and connect to the selected wireless network. (To use the keyboard, see HOW TO USE THE TOUCH SCREEN on page 20.)

When the console is connected to your wireless network, a checkmark will appear next to the wireless network name.

If you are having problems connecting to an encrypted network, make sure that your password is correct. Note: Passwords are case-sensitive.

Note: The console supports unsecured and secured (WEP, WPA™, and WPA2™) encryption. A broadband connection is recommended; performance depends on connection speed.

Note: If you have questions after following these instructions, go to support.iFit.com for assistance.

5. Exit the wireless network menu.

To exit the wireless network menu, touch the back button (arrow symbol).

HOW TO USE THE SOUND SYSTEM

To play music or audio books through the console sound system while you exercise, plug a 3.5 mm male to 3.5 mm male audio cable (not included) into the jack on the right side of the console and into a jack on your personal audio player; **make sure that the audio cable is fully plugged in.** Note: **To purchase an audio cable, see your local electronics store.**

Next, press the play button on your personal audio player. Adjust the volume level by pressing the volume increase and decrease buttons on the right side of the console or the volume control on your personal audio player.

To listen to the console audio with your personal headphones or ear buds, plug your headphones into the headphones jack on the right side of the console.

HOW TO CONNECT AN HDMI CABLE

To show your console screen on a TV or monitor, plug an HDMI cable (not included) into the port on the console and into a port on your TV or monitor; **make sure that the HDMI cable is fully plugged in.** **Note: To purchase an HDMI cable, see your local electronics store.**

THE OPTIONAL CHEST HEART RATE MONITOR

Whether your goal is to burn fat or to strengthen your cardiovascular system, the key to achieving the best results is to maintain the proper heart rate during your workouts. The optional chest heart rate monitor will

enable you to continuously monitor your heart rate while you exercise, helping you to reach your personal fitness goals. **To purchase a chest heart rate monitor, please see the front cover of this manual.**

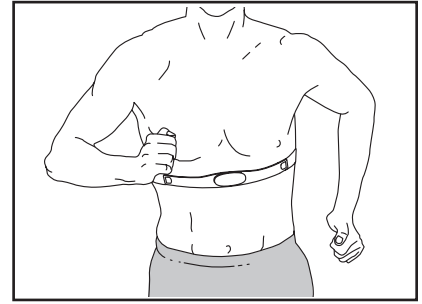

Note: The console is compatible with all Bluetooth Smart heart rate monitors.

MAINTENANCE AND TROUBLESHOOTING

MAINTENANCE

Regular maintenance is important for optimal performance and to reduce wear. Inspect and properly tighten all parts each time the studio cycle is used. Replace any worn parts immediately.

To clean the studio cycle, use a damp cloth and a small amount of mild soap. **IMPORTANT: To avoid damage to the console, keep liquids away from the console and keep the console out of direct sunlight.**

CONSOLE TROUBLESHOOTING

If the console does not turn on, make sure that the power cord is fully plugged in and that the power switch is in the reset position.

If you are having problems connecting the console to a wireless network or if you are having problems with your iFit account or iFit workouts, go to support.iFit.com.

If the Console (10) does not stay in place when it is moved to the desired position, tighten the indicated M8 Locknut (99) slightly until the Console stays in place.

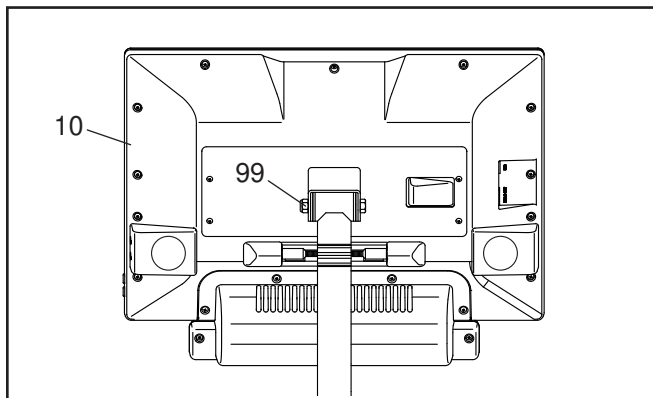

If the console does not boot up properly, or if the console freezes and does not respond, reset the console to the factory default settings. **IMPORTANT: Doing this will erase all custom settings you have made to the console.** Resetting the console requires two

people. First, press the power switch and unplug the power cord. Next, locate the small reset opening (A) near the USB port on the console. Using a bent paper clip, press and hold the reset button inside the opening, and have a second person plug in the power cord and press the power switch. Continue holding the reset button until the console turns on. When the reset operation is complete, the console will turn off and then turn back on. If it does not, press the power switch off and then on again. Once the console turns on, check for firmware updates (see HOW TO CHANGE CONSOLE SETTINGS on page 26). Note: It may take a few minutes for the console to be ready for use.

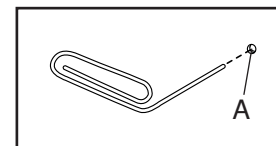

INCLINE SYSTEM TROUBLESHOOTING

If the frame does not move to the correct incline level, see HOW TO CHANGE CONSOLE SETTINGS on page 26 and calibrate the incline system.

HOW TO ADJUST THE LEFT CRANK ARM

If the Left Crank Arm (21) feels loose while you are pedaling, tighten the two M6 x 25mm Screws (96).

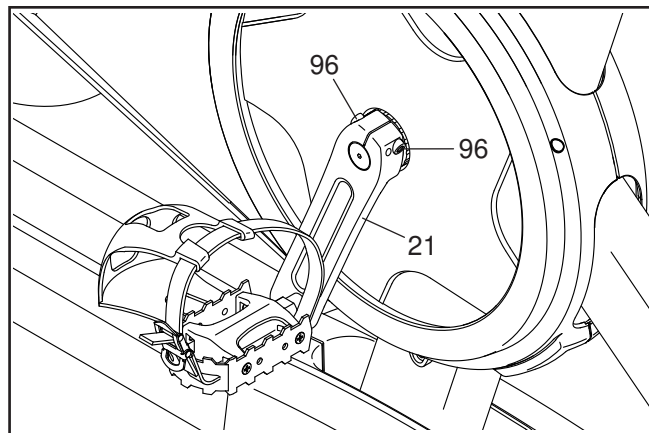

HOW TO ADJUST THE REED SWITCH

If the console does not display correct feedback, the reed switch should be adjusted.

To adjust the reed switch, **first unplug the power cord**. Next, remove the three indicated M4 x 16mm Screws (83) from the Right and Left Shields (30, 32).

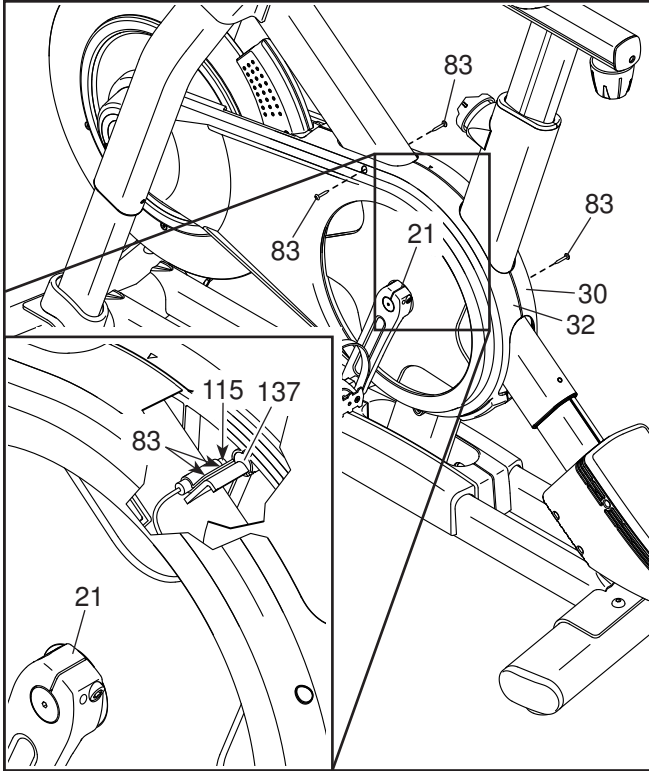

Then, carefully pull the tops of the Right and Left Shields (30, 32) apart a few inches.

See the inset drawing. Slightly loosen the two indicated M4 x 16mm Screws (83). Next, rotate the Left Crank Arm (21) until a Pulley Magnet (137) is aligned with the Reed Switch (115). Slide the Reed Switch slightly toward or away from the Pulley Magnet. Then, retighten the Screws.

Plug in the power cord and rotate the Left Crank Arm (21) for a moment. Repeat these actions until the console displays correct feedback.

When the reed switch is correctly adjusted, reattach the Right and Left Shields (30, 32).

HOW TO ADJUST THE DRIVE BELT

If you feel the pedals slip while you are pedaling, even when the resistance is adjusted to the highest setting, the drive belt may need to be adjusted.

To adjust the drive belt, **first unplug the power cord.** Then, follow the instructions below. Note: The drawings show only the right side of the studio cycle.

Remove the indicated M4 x 16mm Screw (83) and the Shield Cover (31) from each side of the studio cycle.

Next, loosen the M10 Axle Nut (27) on each side of the studio cycle, and tighten the Adjustment Nut (26) on each side of the studio cycle **one half turn**. Then, firmly retighten the M10 Axle Nuts.

Plug in the power cord and pedal the studio cycle to test the adjustment. If necessary, repeat the above actions until the pedals no longer slip.

When the drive belt is properly adjusted, reattach the shield covers.

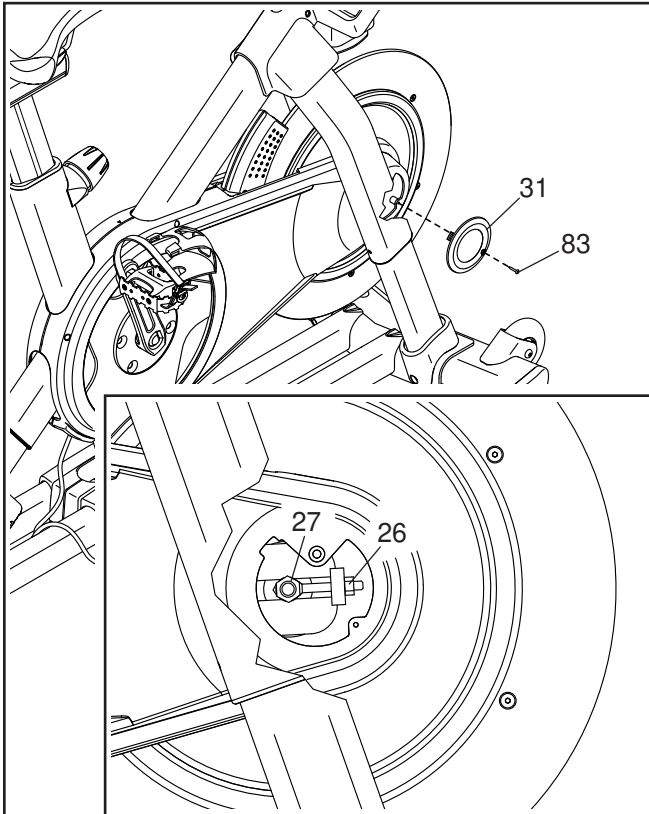

EXERCISE GUIDELINES

⚠️ WARNING: Before beginning this or any exercise program, consult your physician. This is especially important for persons over age 35 or persons with pre-existing health problems.

These guidelines will help you to plan your exercise program. For detailed exercise information, obtain a reputable book or consult your physician. Remember, proper nutrition and adequate rest are essential for successful results.

EXERCISE INTENSITY

Whether your goal is to burn fat or to strengthen your cardiovascular system, exercising at the proper intensity is the key to achieving results. You can use your heart rate as a guide to find the proper intensity level. The chart below shows recommended heart rates for fat burning and aerobic exercise.

165	155	145	140	130	125	115	♥
145	138	130	125	118	110	103	♥
125	120	115	110	105	95	90	♥
<hr/>							
20	30	40	50	60	70	80	

To find the proper intensity level, find your age at the bottom of the chart (ages are rounded off to the nearest ten years). The three numbers listed above your age define your “training zone.” The lowest number is the heart rate for fat burning, the middle number is the heart rate for maximum fat burning, and the highest number is the heart rate for aerobic exercise.

Burning Fat—To burn fat effectively, you must exercise at a low intensity level for a sustained period of time. During the first few minutes of exercise, your body uses carbohydrate calories for energy. Only after the first few minutes of exercise does your body begin to use stored fat calories for energy. If your goal is to burn fat, adjust the intensity of your exercise until your heart rate is near the lowest number in your training zone. For maximum fat burning, exercise with your heart rate near the middle number in your training zone.

Aerobic Exercise—If your goal is to strengthen your cardiovascular system, you must perform aerobic exercise, which is activity that requires large amounts of oxygen for prolonged periods of time. For aerobic exercise, adjust the intensity of your exercise until your heart rate is near the highest number in your training zone.

HOW TO MEASURE YOUR HEART RATE

To measure your heart rate, exercise for at least four minutes. Then, stop exercising and place two fingers on your wrist as shown. Take a six-second heartbeat count, and multiply the result by 10 to find your heart rate. For example, if your six-second heartbeat count is 14, your heart rate is 140 beats per minute.

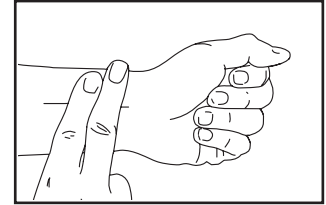

WORKOUT GUIDELINES

Warming Up—Start with 5 to 10 minutes of stretching and light exercise. A warm-up increases your body temperature, heart rate, and circulation in preparation for exercise.

Training Zone Exercise—Exercise for 20 to 30 minutes with your heart rate in your training zone. (During the first few weeks of your exercise program, do not keep your heart rate in your training zone for longer than 20 minutes.) Breathe regularly and deeply as you exercise; never hold your breath.

Cooling Down—Finish with 5 to 10 minutes of stretching. Stretching increases the flexibility of your muscles and helps to prevent post-exercise problems.

EXERCISE FREQUENCY

To maintain or improve your condition, complete three workouts each week, with at least one day of rest between workouts. After a few months of regular exercise, you may complete up to five workouts each week, if desired. Remember, the key to success is to make exercise a regular and enjoyable part of your everyday life.

SUGGESTED STRETCHES

The correct form for several basic stretches is shown at the right. Move slowly as you stretch; never bounce.

1. Toe Touch Stretch

Stand with your knees bent slightly and slowly bend forward from your hips. Allow your back and shoulders to relax as you reach down toward your toes as far as possible. Hold for 15 counts, then relax. Repeat 3 times. Stretches: Hamstrings, back of knees and back.

2. Hamstring Stretch

Sit with one leg extended. Bring the sole of the opposite foot toward you and rest it against the inner thigh of your extended leg. Reach toward your toes as far as possible. Hold for 15 counts, then relax. Repeat 3 times for each leg. Stretches: Hamstrings, lower back and groin.

3. Calf/Achilles Stretch

With one leg in front of the other, reach forward and place your hands against a wall. Keep your back leg straight and your back foot flat on the floor. Bend your front leg, lean forward and move your hips toward the wall. Hold for 15 counts, then relax. Repeat 3 times for each leg. To cause further stretching of the achilles tendons, bend your back leg as well. Stretches: Calves, achilles tendons and ankles.

4. Quadriceps Stretch

With one hand against a wall for balance, reach back and grasp one foot with your other hand. Bring your heel as close to your buttocks as possible. Hold for 15 counts, then relax. Repeat 3 times for each leg. Stretches: Quadriceps and hip muscles.

5. Inner Thigh Stretch

Sit with the soles of your feet together and your knees outward. Pull your feet toward your groin area as far as possible. Hold for 15 counts, then relax. Repeat 3 times. Stretches: Quadriceps and hip muscles.

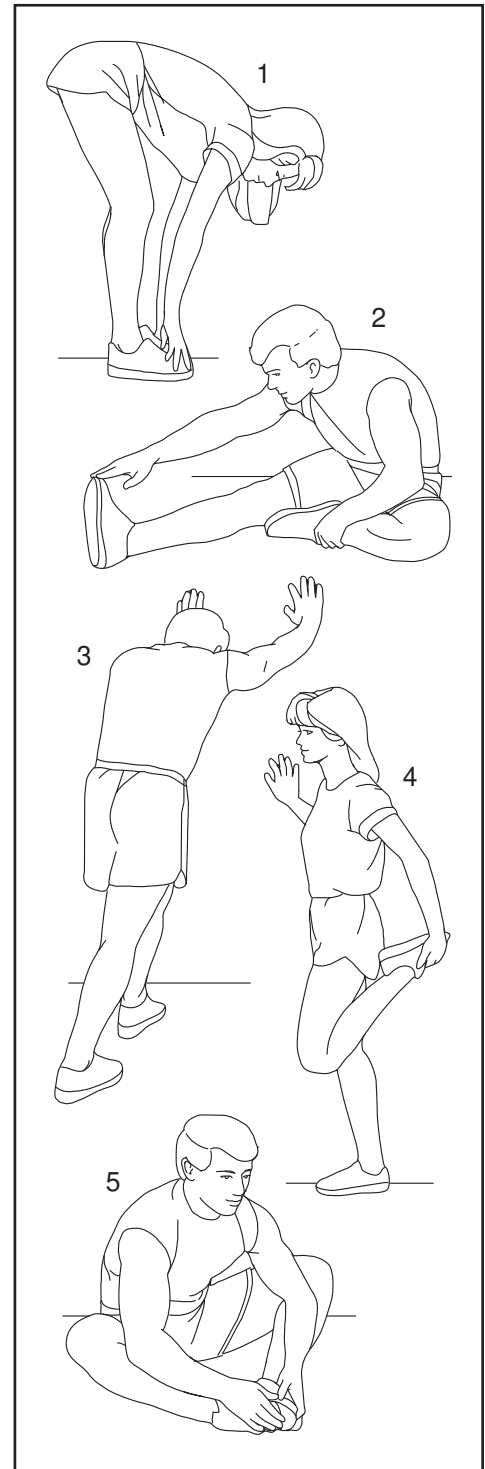

NOTES

PART LIST

Model No. NTEVEX14718.0 R0918A

Key No.	Qty.	Description	Key No.	Qty.	Description
1	1	Frame	51	1	Resistance Disc
2	1	Base	52	1	Lower Saddle Clamp
3	1	Front Stabilizer	53	1	Upper Saddle Clamp
4	1	Rear Stabilizer	54	1	Saddle
5	1	M6 Shoulder Screw	55	6	Anchored Zip Tie
6	2	Pivot Clamp	56	1	Pedal Set
7	1	Handlebar Post	57	9	M4 x 12mm Screw
8	1	Console Support	58	2	Upper Leg
9	1	M8 x 32mm Screw	59	2	Lower Leg
10	1	Console	60	4	M4 x 8mm Screw
11	1	Console Bracket	61	2	M8 Washer
12	6	M4 x 10mm Machine Screw	62	2	Leg Sleeve
13	1	Saddle Post	63	2	Frame Bearing
14	2	Hand Weight	64	2	Leg Cover
15	1	M6 Crank Screw	65	1	Ground Screw
16	1	Pulley	66	4	Large Leg Bushing
17	4	M4 x 14mm Screw	67	1	Carriage
18	4	M10 x 20mm Flat Head Bolt	68	2	Leg Spacer
19	1	Crank/Right Crank Arm	69	4	Small Leg Bushing
20	1	Pivot Axle	70	1	Right Grip
21	1	Left Crank Arm	71	1	Left Grip
22	1	Flywheel Assembly	72	1	Right Control
23	1	Handlebar Cap	73	1	Left Control
24	2	Pivot Bushing	74	1	Shaft Cover
25	1	Drive Belt	75	1	Shaft Cover Sleeve
26	2	Adjustment Assembly	76	4	Stabilizer Cap
27	2	M10 Axle Nut	77	2	Foot
28	2	Post Clamp	78	2	Leveling Foot
29	1	Right Base Cover	79	1	Controller
30	1	Right Shield	80	1	Controller Cover
31	2	Shield Cover	81	4	M4 x 8mm Machine Screw
32	1	Left Shield	82	1	Resistance Motor
33	1	Right Disc	83	27	M4 x 16mm Screw
34	1	Right Incline Motor Cover	84	4	M4 x 12mm Flange Screw
35	1	Left Incline Motor Cover	85	2	Post Knob Cap
36	1	Upper Incline Motor Cover	86	3	Clip Nut
37	1	Left Disc	87	2	Incline Motor Bushing
38	1	Hand Weight Tray	88	1	Incline Motor Spacer
39	1	Handlebar Post Cap	89	1	Incline Motor
40	1	Accessory Tray	90	1	Magnet Bracket
41	1	M8 Saddle Screw	91	1	Right Magnet Bracket Cover
42	1	Saddle Nut	92	1	Left Magnet Bracket Cover
43	2	Carriage Cap	93	4	M8 x 12mm Patch Screw
44	3	One-wire Grommet	94	1	M10 x 52mm Bolt
45	1	Right Saddle Post Sleeve	95	1	M10 Jam Nut
46	1	Left Saddle Post Sleeve	96	2	M6 x 25mm Screw
47	1	Right Handlebar Post Sleeve	97	1	Handlebar
48	1	Left Handlebar Post Sleeve	98	2	M8 x 50mm Bolt
49	2	Wheel	99	3	M8 Locknut
50	1	Adjustment Arm	100	2	Post Knob

Key No.	Qty.	Description	Key No.	Qty.	Description
101	1	Carriage Knob	128	2	M5 Nut
102	1	Lock Spring	129	1	M5 x 8mm Screw
103	2	M4 x 10mm Screw	130	1	M3 x 8mm Screw
104	4	M10 Clamp Screw	131	1	Adjustment Block
105	12	M10 x 20mm Screw	132	2	M4 x 10mm Blunt Screw
106	1	M8 x 85mm Bolt	133	2	M3 x 20mm Screw
107	2	M4 x 14mm Machine Screw	134	1	Plastic Spacer
108	3	M6 Washer	135	5	M10 Locknut
109	1	Bracket Mount	136	3	M4 x 16mm Button Screw
110	2	Two-wire Grommet	137	2	Pulley Magnet
111	2	Upper/Lower Pivot Disc	138	2	M6 x 12mm Screw
112	1	Center Pivot Disc	139	1	Thrust Washer
113	2	Inner Pivot Disc	140	1	Brake Knob Cap
114	2	Outer Pivot Disc	141	1	M6 Locknut
115	1	Reed Switch/Wire	142	1	Brake Knob
116	1	Reed Switch Clip	143	1	Lower Brake Bushing
117	1	Left Base Cover	144	1	Spring Stop
118	1	Power Switch	145	1	Brake Spring
119	1	Power Cord Grommet	146	2	M4 x 5mm Screw
120	1	Power Cord	147	1	Brake Shaft
121	1	Shoe Pin	148	1	Roll Pin
122	1	Lower Wire	149	1	E-ring
123	1	Upper Wire	150	1	Brake Shoe
124	1	Extension Wire	151	6	M4 x 12mm Blunt Screw
125	1	Control Wire	152	1	Upper Brake Bushing
126	6	M8 x 12mm Screw	*	–	User's Manual
127	6	M8 Large Washer	*	–	Assembly Tool

Note: Specifications are subject to change without notice. For information about ordering replacement parts, see the back cover of this manual. *These parts are not illustrated.

EXPLODED DRAWING A

Model No. NTEVEX14718.0 R0918A

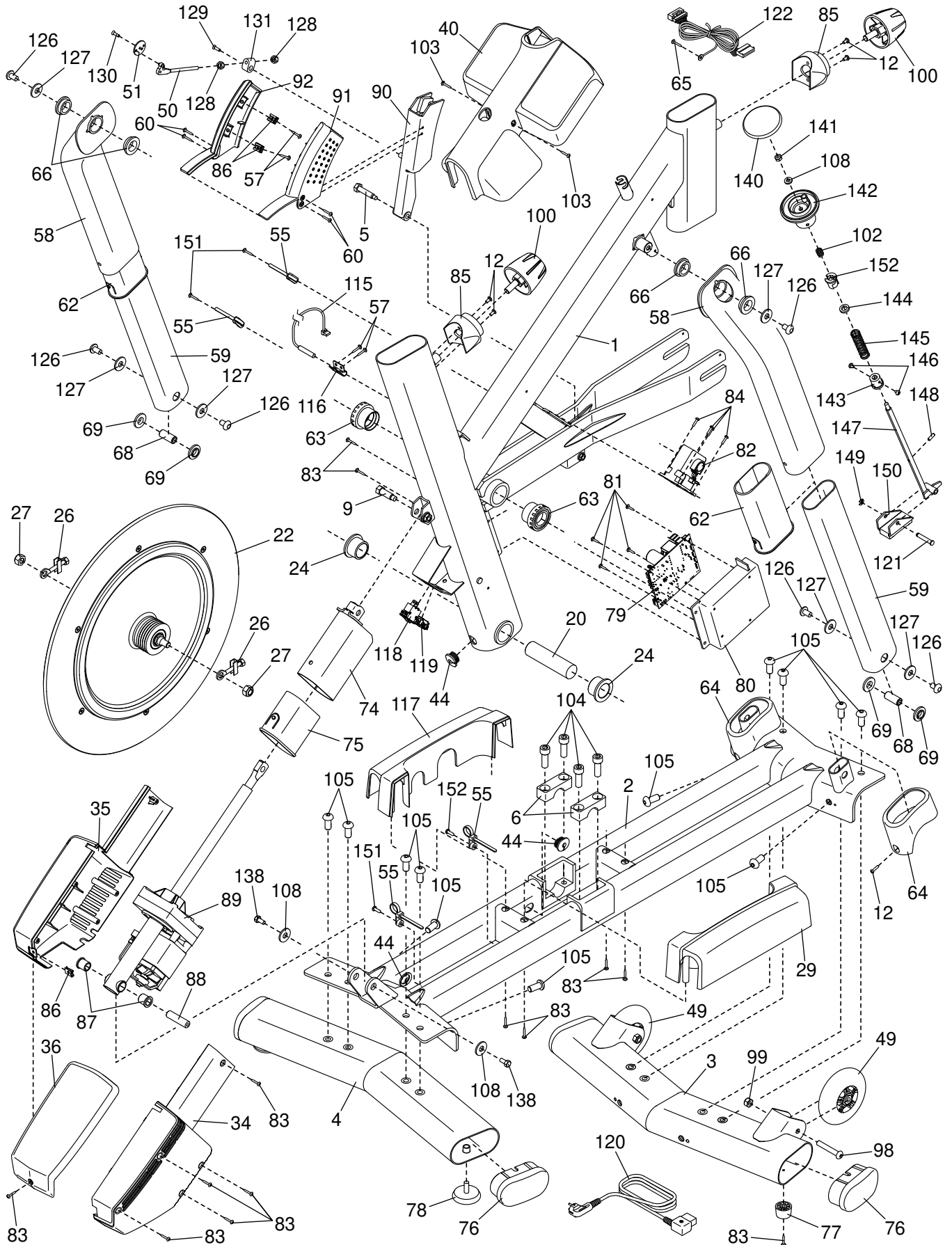

ORDERING REPLACEMENT PARTS

To order replacement parts, please see the front cover of this manual. To help us assist you, be prepared to provide the following information when contacting us:

- the model number and serial number of the product (see the front cover of this manual)
- the name of the product (see the front cover of this manual)
- the key number and description of the replacement part(s) (see the PART LIST and the EXPLODED DRAWING near the end of this manual)

RECYCLING INFORMATION

This electronic product must not be disposed of in municipal waste. To preserve the environment, this product must be recycled after its useful life as required by law.

Please use recycling facilities that are authorized to collect this type of waste in your area. In doing so, you will help to conserve natural resources and improve European standards of environmental protection. If you require more information about safe and correct disposal methods, please contact your local city office or the establishment where you purchased this product.

